

The 2nd International Conference on Water Resources in Arid Environments
King Saud University Riyadh 2006

**THE SEAWATER GREENHOUSE
COOLING, FRESH WATER AND FRESH PRODUCE FROM SEAWATER**

Charlie Paton † Philip Davies*

† Seawater Greenhouse Ltd, 2A Greenwood Road, London E8 1AB, U.K.

charlie@seawatergreenhouse.com

www.seawatergreenhouse.com

*School of Engineering and Applied Science, Aston University

Birmingham B4 7ET UK

P.A.Davies@aston.ac.uk

ABSTRACT

The Seawater Greenhouse uses solar energy, seawater and the humidity of the ambient air to provide desalination and cooling. Its primary purpose is to provide fresh water together with an economic and sustainable means of cultivating high quality crops, year round, in hot, arid coastal regions.

The Seawater Greenhouse integrates cooling and solar distillation in one structure. Following earlier projects in Tenerife and the United Arab Emirates, a 1000 m² Greenhouse has been constructed near Muscat, Oman, successfully demonstrating the potential for cultivating crops in one of the hottest and driest regions on earth. Greenhouse cultivation in this region normally depends on fresh water for cooling and irrigation. In common with many other parts of the world, this has led to over abstraction of groundwater, causing saline intrusion and loss of fertile land. The Seawater Greenhouse provides an alternative approach that relies entirely on seawater rather than ground water, and may thus be used in coastal regions where cultivation is otherwise difficult or impossible. The approach uses energy from the sun, the sea and the atmosphere, which combined with efficient use of water, enables crops to be grown year round.

All materials used in the construction of the Greenhouse are both low cost and 100% recyclable. Interestingly, we have identified a process whereby the cardboard evaporators are slowly reinforced over time with calcium carbonate, which precipitates out of the seawater, similar to the way that

coral or seashells are formed. We have also developed an all plastic (polythene) heat exchanger to replace the more conventional aluminium / copper nickel fin and tube heat exchanger which condenses the fresh water from the humid air. Apart from lower cost, the polythene is totally resistant to corrosion, and while it should have an almost indefinite life, is also 100% recyclable.

In addition to agricultural applications, the process may be adapted for cooling buildings on a commercial scale with the production of fresh water as a by-product. Such applications are subject to the availability of favourable geographic and climate conditions, such as low relative humidity and access to cool seawater, usually found at a depth in the sea. The Red Sea Coast of Saudi Arabia has these conditions in many locations.

SUMMARY

The Seawater Greenhouse uses sunlight and seawater to provide desalination and cooling. Its primary purpose is to provide fresh water together with an economic and sustainable means of cultivating crops, year round, in hot, arid coastal regions.

Following earlier projects in Tenerife and the United Arab Emirates, a 1000 m² Greenhouse has been constructed near Muscat, Oman, successfully demonstrating the potential for cultivating crops in one of the hottest and driest regions on earth. In common with many other arid parts of the world, the region has experienced over abstraction of groundwater, causing saline intrusion and loss of fertile land. The Seawater Greenhouse provides an alternative approach that relies entirely on seawater rather than ground water, and may thus be used in coastal regions where cultivation is otherwise difficult or impossible due to lack of water, high temperatures or both. The approach, combined with efficient use of water, enables high value crops to be grown year round.

Interestingly, the cooler and more humid conditions enable crops to grow with very little water, and as the crops are not stressed by excessive transpiration, the yield and quality is higher. For example, In Oman, the winter to summer evapo-transpiration rates range from 4-11 litres / m² / day, whereas in the Seawater Greenhouse they are reduced to less than 1 to 1.5 Litres / m² / day. This represents a four to eight-fold saving. It is interesting to note that a solution to the world's water shortage may not be to produce more water, but to use less water, yet grow better crops.

When compared with conventional greenhouse cooling and desalination, the Seawater Greenhouse uses very little electrical power, as the thermodynamic work of cooling and distillation is performed by energy from the sun and the wind. The modest electrical demand enhances the potential for driving the entire process using photovoltaic power, yet without the need for batteries, inverters etc. Such a development would enable food and water self-sufficiency, especially in remote, arid regions.



Cardboard evaporator, reinforced by CaCO_3 bio-mineralisation from seawater, and polythene tube heat exchanger.



Seawater Greenhouse May 2005 Cucumbers are successfully growing throughout the hottest summer months.

INTRODUCTION

Agriculture accounts for around 70% of all fresh water consumed worldwide. In the Middle East / North Africa region, this goes above 85% and in Oman it is 94%¹. Unprotected outdoor cultivation can demand more than 4 times the amount of irrigation water, as compared with shaded or more protected cultivation.

Evaporatively cooled, 'pad and fan' greenhouses provide a cooler and more humid climate, so that yields are higher and certain crops can be grown year round, even during the summer months which are too hot for unprotected cultivation.

The Sultanate of Oman, like every country in the Middle East, is facing decreasing ground water and increasing salinity. The coastal plain of the Batinah Region where traditionally most agriculture takes place, suffers from a lowering water table and the consequent saline intrusion. Some farmers are pumping ground water from a depth of 100 meters while many farms on the coast have been abandoned due to toxic levels of salinity.

Little incentive for water use efficiency combined with low rainfall (average of 100 mm. per year) has the result that farmers extract beyond the natural refill of the aquifers, which has led to falling groundwater tables. This causes seawater to intrude inland. As a consequence, farmers see a gradual decline in marketable produce, both in quality and in quantity, leading to the point where agriculture is no longer viable or possible.

In Oman, as in many parts of the world, desalination is the only method of meeting the shortfall. Yet desalination is expensive in terms of energy. Even with the more efficient desalination plant, 1 kg of oil can only yield about 1000 kg of freshwater. Using standard methods of irrigation, this amount of water may only yield about 1 or 2 kg of edible crop (see Figure 1 below).

¹ World Bank: *From Scarcity to Security, Averting a Water Crisis in the Middle East and North Africa*

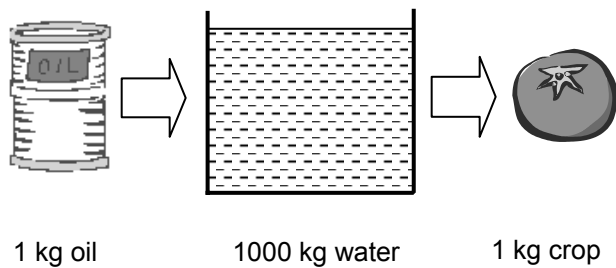

Figure 1: Basic economy of conventional desalination for agricultural use.

Against this background, the College of Agriculture of Sultan Qaboos University contracted with Seawater Greenhouse Ltd to collaborate on a feasibility study² to assess the potential and benefits of implementing the Seawater Greenhouse process. This study, which was part funded by the Middle East Desalination Research Center, indicated that while the economic viability depended on the value of the crops that could be grown, the process itself is well suited to the coastal climate conditions of Oman.

The University then sought funding to develop and test the concept. An award was granted to the project in 2002 by HM Sultan Qaboos. Seawater Greenhouse Ltd were contracted to design and construct a Seawater Greenhouse, optimised for the conditions on the Batinah Coast, while the Colleges of Agriculture and Engineering undertook responsibility for its management and operation.

² Seawater Greenhouse Development for Oman: Thermodynamic Modelling and Economic Analysis

PROJECT DESIGN

While the process design was based to some extent on previous pilot projects in Tenerife and Abu Dhabi, The primary objectives of the Oman design evolved in favour of:

1. lower cost and simpler construction techniques, such that it would demonstrate commercial viability and could be assembled using unskilled labour,
2. minimum operating cost, primarily for electricity to drive the pumps and fans,
3. optimised performance.

These three objectives, illustrated at the corners of the triangle below, tend to conflict with each other. In general, cheaper solutions tend to have inferior performance when compared to more expensive ones. Similarly, higher performance is usually associated with greater energy consumption.

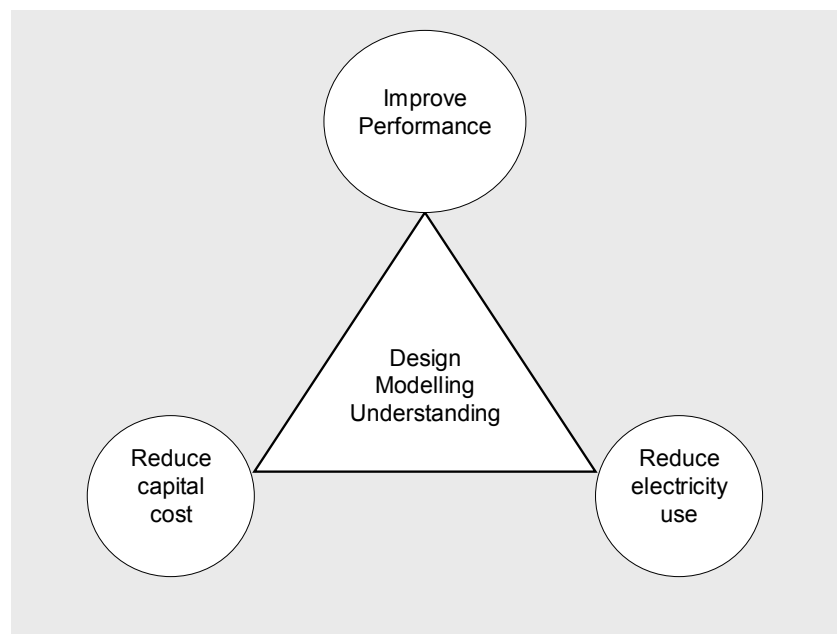

The solution to this conflict, shown within the triangle above, lies in:

1. Gaining a better understanding of the processes.
2. Using models and experiments to answer ‘what if’ questions.
3. Translating this knowledge through design.

As the diagram below illustrates, the process is reasonably simple. The air going into the greenhouse is first cooled and humidified by the first evaporator. This provides good climate conditions for the crops in the growing area. As the air leaves the growing area, it passes through the second evaporator which has hot seawater flowing over it. Thus the air is made much hotter and more humid, such that fresh water will condense out of the air-stream when it is cooled.

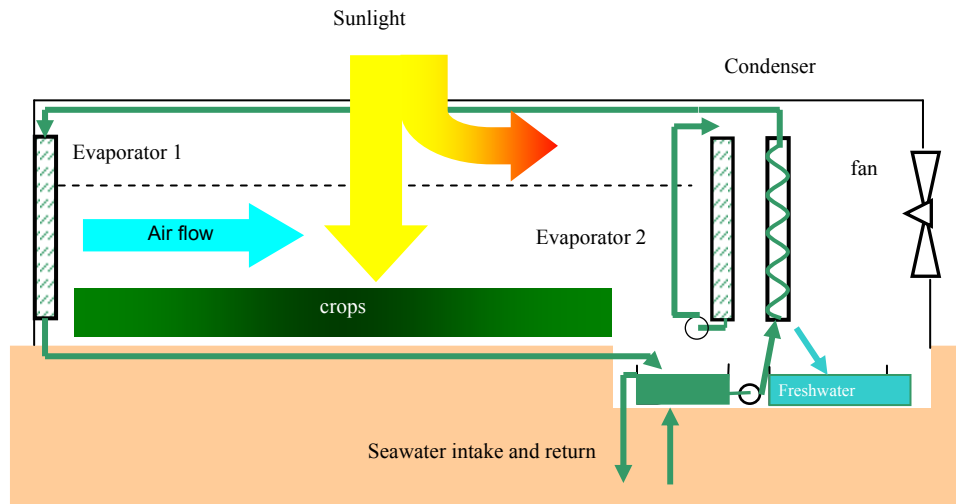

Figure 2 Seawater Greenhouse schematic

In a sense, the simplicity of the process mimics the natural hydrological cycle where seawater heated by the sun, evaporates, forms clouds and returns to the earth as rain or dew. However, just like the weather, and the inherent difficulty of forecasting it, the details of the process are complex as they are constantly changing over time. Solar radiation, windspeed and wind direction, temperature and relative humidity are constantly changing in relation to each other, both throughout the day and throughout the seasons. It is these changing conditions that both drive and affect the performance of the Greenhouse. Accordingly, small changes to the design can have a significant effect on its performance. The large number of processes occurring simultaneously means that simple analytical models are not sufficiently accurate and that computer models have to be used.

To help optimise the process and answer ‘what if?’ questions, we have developed two computer models to enable iterative simulations to be performed. The first model ‘Waterworks’ describes the thermodynamics of the process and uses mathematical modelling software based on the Matlab / Simulink platform. It takes into account several well-understood physical processes:

- Evaporative cooling of water and air
- Solar heating
- Heat loss from the building
- Transpiration based on the Penman equation
- Heat transfer in a heat exchanger
- Ventilation driven by a fan with assistance from the wind

Each process is described within a block of the model. The blocks are linked together in such a way that the mass and energy flows in and out of the blocks sum to zero, in accordance with the 1st Law of Thermodynamics.

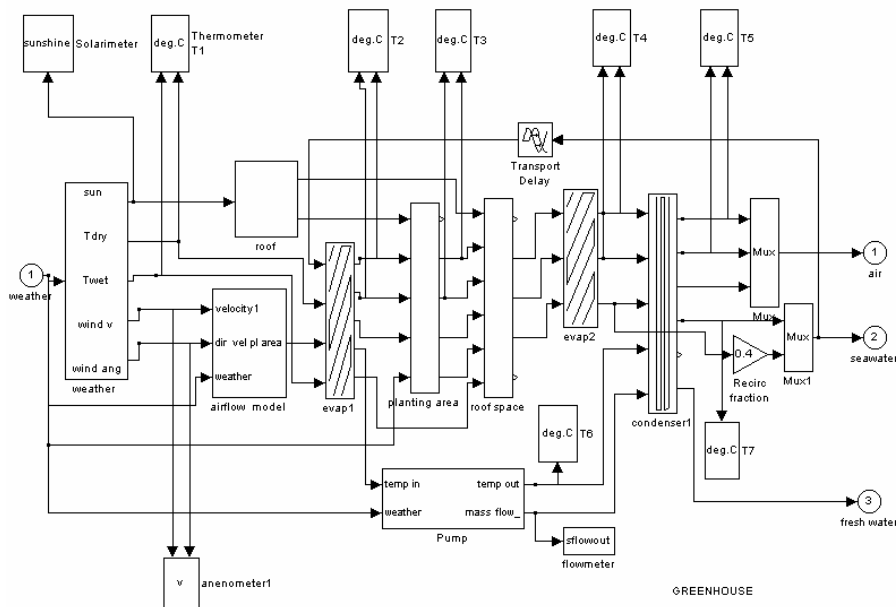

Figure 4: Overview of the thermodynamic model.



Figure 5: Parameter window for Waterworks, mathematical modelling program.

Meteorological data, to the WMO standard for synoptic observations is used as the input to the model and the process is then 'driven' by these conditions. Greenhouse design parameters, such as length, width, height, orientation, together with flow rates of air and water can be adjusted, and the effect analysed on the results window.

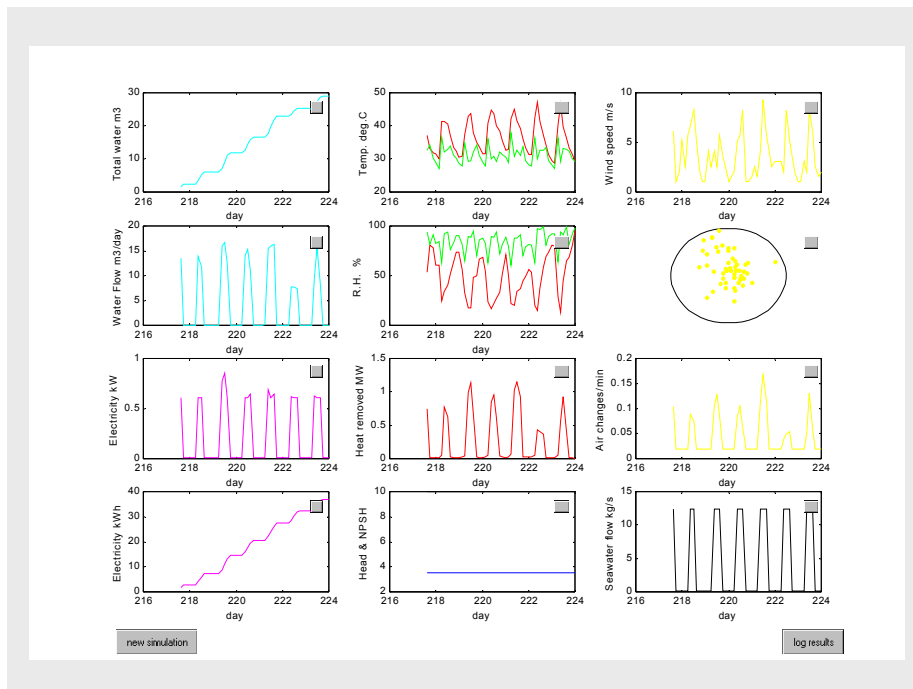

Figure 6: Results window for Waterworks, mathematical modelling program.

A period of days, weeks or a whole year can be selected for analysis. In the results window in Figure 6 above, the performance over 6 days can be seen. The graphs illustrate the main parameters of interest, such as daily and cumulative water production, temperatures and humidities, air flow rates under the influence of wind, and power consumption etc.

Our two previous pilot greenhouse projects in Tenerife and Abu Dhabi were equipped with a data logger and a comprehensive array of sensors. This has enabled the model to be validated against 'real' conditions, and the model gives good agreement with observations as the following graph illustrates:

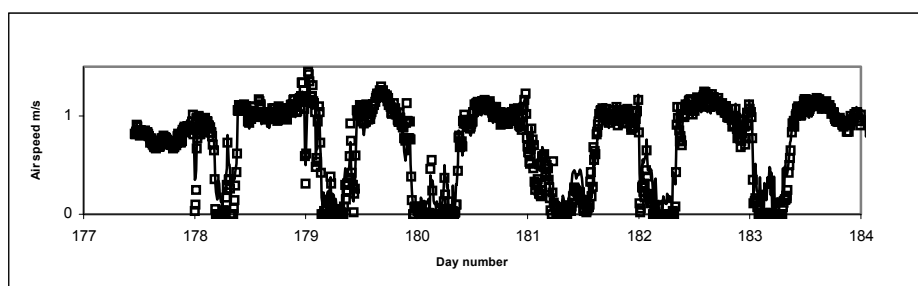

Figure 7: Verification of the wind driven airflow model against measurements of airspeed at the condenser of the Tenerife Greenhouse. The black line is predicted by the model and the square dots are measured values.

While the 'Waterworks' program provides valuable data to guide the design, it does not answer the more intricate questions of airflow and temperature distribution within the greenhouse. To answer such questions and help refine the design further, we have used Computational Fluid Dynamic (CFD) software from Flo-Vent.

Two examples are shown below. The air temperature field shows a higher velocity at ground level than in the roof which is best for the crops. Air is somewhat stagnant and hot in the roof area, but note that further towards the back it is somewhat cooler, suggesting that some of the heat is wasted.

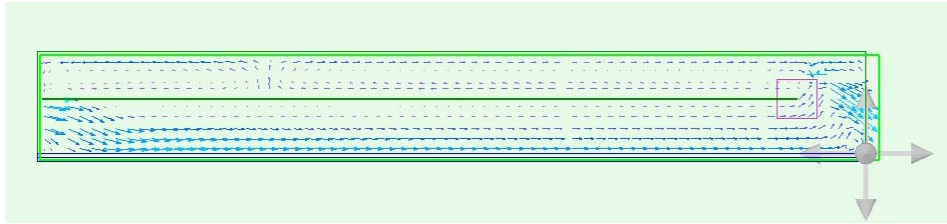

Figure 8: Air velocity profile through a section of the greenhouse

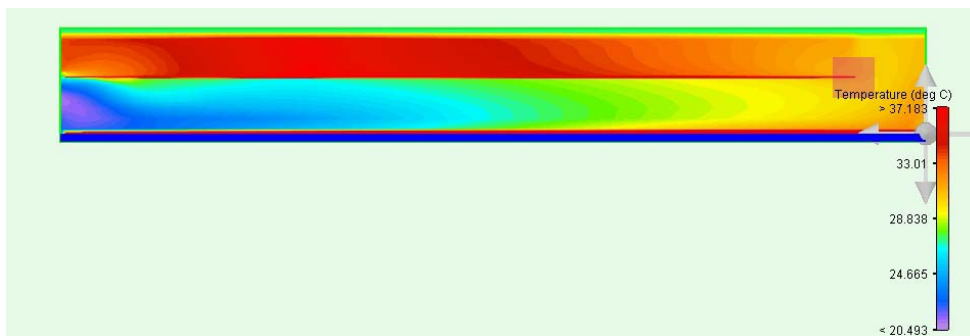
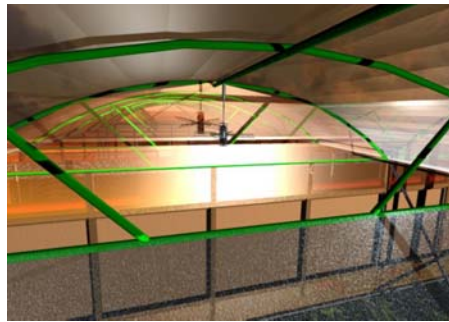
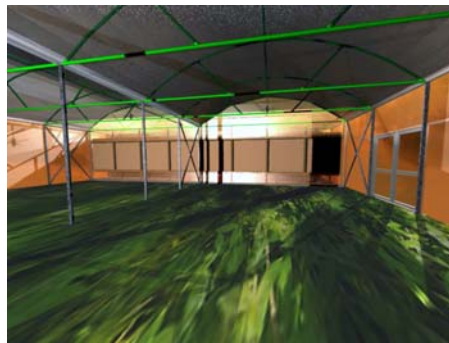
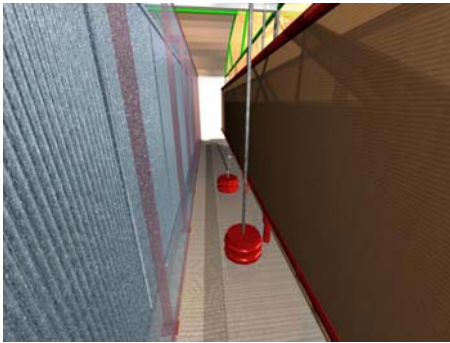

Figure 9: Temperature profile through a section of the greenhouse

These graphs illustrate for example, that if we wish to have a more uniform temperature profile across the length of the greenhouse, it should either be made shorter, or the air flow rate increased.

DETAILED DESIGN

The thermodynamic and CFD models provide guidelines for the shape, layout and orientation of the Greenhouse for optimum performance, but these guidelines have to be converted into a practical and achievable structure, using low cost and commonly available materials, such as; steel, wood, polythene and cardboard. Accordingly, a number of engineering and cost constraints are encountered. Accordingly, the design has evolved in favour of a simplified structure based on a stretched version of standard widespan polytunnels. This design is preferred because of low cost and to make best use of the hot air accumulated within the roof compartment.



Rendered Autocad drawings of the Oman Greenhouse design.

In parallel with the structural design, we have incorporated a new, all plastic heat exchanger, the design of which we had been working on for two years previously. While plastic is generally not considered suitable for heat exchangers due to its poor thermal conductivity, observations led to experiments that offset this objection. Essentially in this application, it is the thermal resistance of the air, rather than the heat exchanger material itself that causes the greatest resistance to heat transfer. By using a large array of very thin walled polythene tubes, the surface area could be increased at much lower cost than could be achieved with metals that resist seawater corrosion, such

as cupri-nickel, stainless steel and titanium. In addition, the tubes and fittings could be transported 'flat packed' and assembled on site, using local labour, thus reducing the cost further.



Assembly on site of the 'Watermaker' all plastic condenser.

CONSTRUCTION

The Oman Seawater Greenhouse was prefabricated in the UK and shipped out to Oman in December 2003. Construction commenced in January 2004 and was completed in one month by a team of 4 engineers from the UK together with local labour in Oman.



CROP TRIALS

For the first crop trial, cucumbers were planted in March to test the growing conditions over the summer. Subsequently, a study was undertaken to compare water use in the Seawater Greenhouse with two conventional evaporatively cooled greenhouses. The study showed that the Seawater Greenhouse used 4-8 times less water than the conventional greenhouses, yet with equal or improved crop quality and yield. The cooler and more humid conditions enabled crops to be grown year round, even during the hottest summer months. It is interesting to note that one solution to water shortage may not be to produce more water, but to use less water, yet grow better crops.

Interestingly, it was found that the use of pesticides was not required in the Seawater Greenhouse, while crops in the comparison greenhouses had to be sprayed for whitefly 7 times during the growing seasons. The reasons for this are not entirely clear, although it was felt that the salt water evaporators had an air scrubbing effect, such that any airborne insects or contaminants were washed out of the incoming ventilation air. A coastal location is a further benefit as the air coming off the sea carries much fewer pests and contaminants.

FUTURE DIRECTIONS

While energy efficiency is not currently a major issue in Oman, owing to the country's reserves of fossil fuel, it is a major issue in most other arid regions where the Seawater Greenhouse may be of benefit. To produce fresh water from seawater is an energy intensive process whichever technology is used, and generally it is a viable option only to countries with abundant reserves of fossil fuels.

Arid regions invariably have sunny climates and usually excessive heat, such that it has long been the wish of many countries to use solar energy for converting seawater to fresh water. The most obvious method is solar distillation, and while a considerable amount of literature, dating back to the Arab alchemists of 1551, exists on solar stills, the technique represents only a small fraction of worldwide desalination capacity, which is driven almost exclusively by fossil fuel processes.

This can partly be explained by the fact that a well designed solar still can produce at best around 4 litres of water a day from each square meter still area. This small output, relative to the capital and operating cost of the still, is only viable in a very limited number of situations.

In terms of water production, the Seawater Greenhouse process in its simplest form produces even less than this, at around 1-2 litres of water per square metre a day. However its contribution is not so much the volume of water it produces, but the cooler and more humid conditions it provides enable crops to grow with very little water, and as the crops are not stressed by excessive transpiration, the yield and quality is higher. For example in Oman, the winter to summer evapotranspiration rate ranges from 4-11 litres / m² / day, whereas in the Seawater Greenhouse it is reduced to between less than 1 and 1.3 Litres / m² / day. This represents a four to eight-fold saving. As the proportion of water used for agriculture across the Middle East / North Africa region exceeds 80% of the total renewable supply, the potential saving here could be of significance.

Unlike solar stills, the Seawater Greenhouse needs a supply of electricity to drive the pumps and fans that cool the growing area and make water. However, the power requirement is very modest as most of the thermodynamic work of distillation is performed by the sun and the wind. A 1000m² Greenhouse requires around 2kW of electrical power yet removes 800kW of heat, cooling the ventilation air and distilling sufficient fresh water for the crops. As the demand for electrical power is proportional to sunlight, we propose in future to meet this electrical need using photovoltaic panels, yet without batteries and inverters etc. In addition to CO₂ savings, this will allow off-grid and remote communities to produce crops and fresh water.

Saudi Arabia offers great potential for the Seawater Greenhouse, primarily on the Red Sea coast and islands. Although the region experiences quite high temperatures and humidity, there is still considerable potential for evaporative cooling as the chart below illustrates.

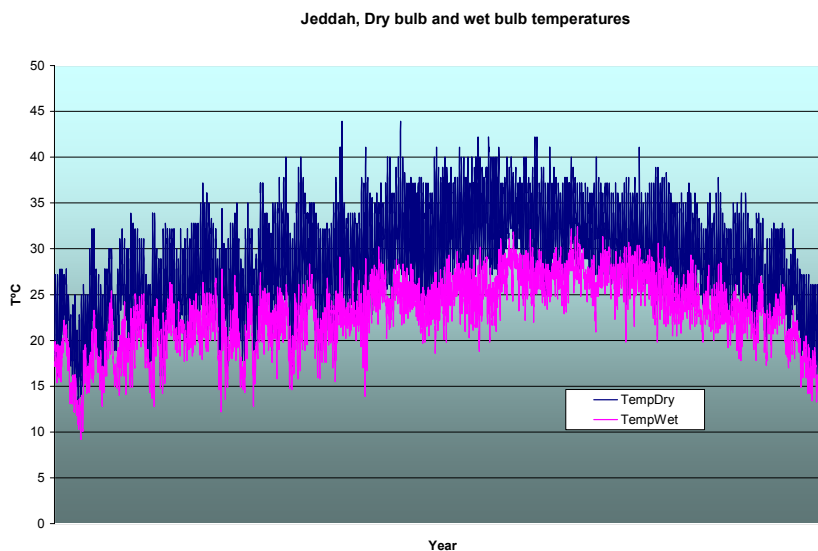

Figure 10 Comparison of average dry bulb and wet bulb temperatures throughout the year in Jeddah

The wet bulb temperature shows the temperature that is achievable with evaporative cooling. With an average of 22.7°C throughout the year, many types of crops may be grown, although the maximum summer wet bulb temperature of 32.4 will limit the choice to heat tolerant varieties. Large tracts of flat, coastal land together with a reasonably strong prevailing wind contribute to the viability.

The water of the Red Sea offers further potential for cooling, as while the surface waters are quite hot in summer, the temperature rapidly falls to around 21.5°C with increasing depth. This abundant source of cool water remains constant throughout the year and may additionally used for air conditioning in addition to producing fresh water.

The concept may be illustrated by a recent project for redevelopment of the port city of Las Palmas de Gran Canaria, in a collaboration with the UK architects Nick Grimshaw & Partners. Here the 'Teatro del Agua', together with the proposed new waterfront buildings, utilise seawater taken from a depth to create cooling and fresh water, and eliminate the need for mechanical air conditioning.. The process is based on the Seawater Greenhouse concept but the principles are not limited to

agriculture and may readily be adapted to the built environment. Indeed many of the principles have been in use since antiquity to moderate the climate in hot, arid regions.



The Alhambra in Spain is a good example of traditional solutions in Islamic architecture for providing climate control, where the plants, fountains and flowing water provide cooling for the spaces that overlook the gardens.

Such solutions have inspired this proposed development which covers an area of about 400 000 m². In the sunny climate of the Canary Islands, the amount of solar energy falling on this area is very large, reaching about 320 MW. If, for example, just 1/10th of that energy were used to distil fresh water from seawater, around 300 m³ per day of freshwater may be produced.

Gran Canaria has abundant sunshine year round yet with moderate temperatures for its latitude (which is the same as Kuwait). It also lies close to very deep, cold seawater. Within 4 km of the harbour, the seabed falls rapidly to a depth of 1000 metres, where the water temperature is 9°C. The mean wind speed of 7m/s and NNE direction are remarkably constant year round, and can thus be harnessed to drive the ventilation. These conditions may all be used to provide sustainable and low cost methods of cooling, and the production of fresh water. This energy is renewable, carbon free and unlimited in its abundance, as the cooling process is driven by solar energy evaporating surface seawater, and thermal stratification with depth. The potential exists to produce fresh water at less cost than any other desalination system and using only renewable energy for the process, with cool air as a free by-product. The water produced is distilled, similar to dew or rain, and does not need any chemical treatment, unlike all other desalination processes. The buildings are thus self-sufficient in water, and the surplus is sufficient to irrigate some 50,000 m² of gardens.

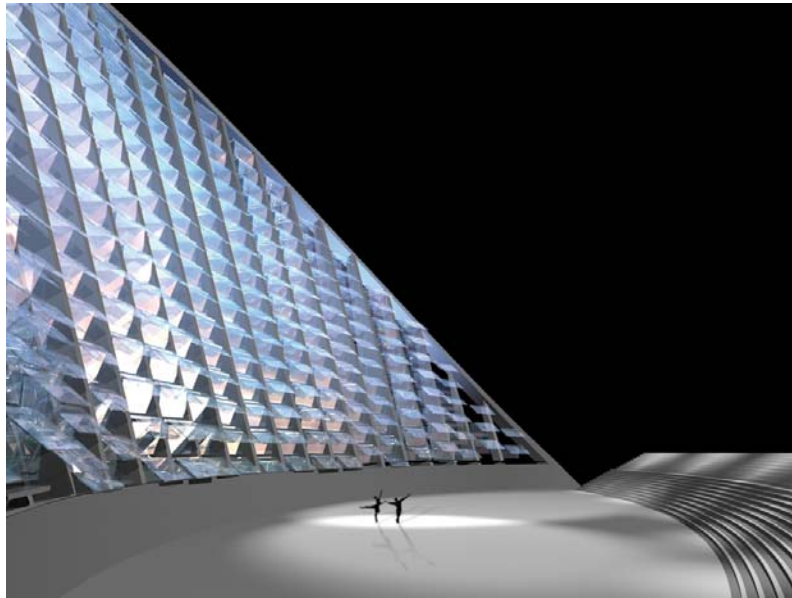
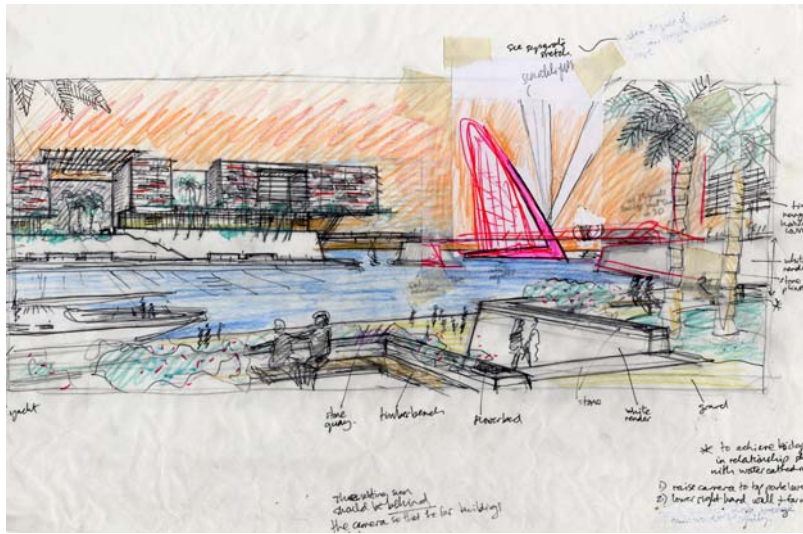

Detail of the 'Teatro del Agua', a water producing outdoor theatre concept for Gran Canaria



The focus of the scheme is a Water Theatre, which is a demonstration of the sustainable design principles that drive the masterplan. The intention is to use the natural resources of the island; abundant sunshine, cold water from a depth in the sea, and a steady prevailing wind that can be harnessed for cooling the air the production of fresh water. The result could be the world's first harbourside development that is entirely cooled and irrigated by natural means.